

## MINISTART Softstarter With Softstop GE 9015



0223498



- Increases life of squirrel cage motors and mechanical drives
- Easily fitted to existing installations
- 3-phase control softstart and softstop
- For motors up to 55 kW
- Start current limited to 2 to 3 times rated motor current
- Semiconductors bridged after softstart
- Adjustable ramp time, starting torque and deceleration time
- Integrated temperature monitoring of semiconductors
- Thermistor temperature monitoring of the motor
- 7.5 ... 22 kW: enclosure width 304 mm
- 30 ... 55 kW: enclosure width 335 mm

### Function Diagram

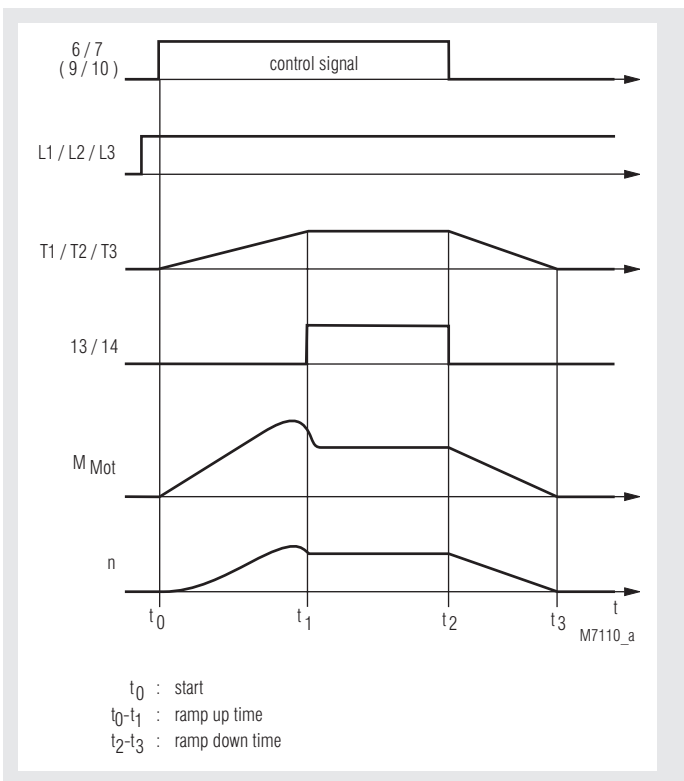

### Approvals and Marking



### Applications

- Motors with gear, belt or chain drive
- Fans, pumps, conveyor belts, compressors
- Woodworking machines, centrifuges
- Start current limiting on 3-phase motors
- Reduces on off current on transformers and P.S.U.'s

### Function

Softstarts are electronic devices designed to enable 1-phase or 3-phase induction motors to start smoothly. The GE 9015 slowly ramps up the current on three phases, therefore allowing the motor torque to build up slowly. This reduces the mechanical stress on the machine and prevents damage to conveyed material.

When the motor is up to full speed the semiconductors in GE 9015 are bridged to prevent internal power losses and heat build up. In addition GE 9015 allows a softstop function prolonging the stop time of the motor, preventing high counter torques from abruptly stopping the motor.

### Indication

LED yellow	ON	= power connected
LED red	ON	= fault
LED green	ON	= power semiconductors bridged

### Block Diagram

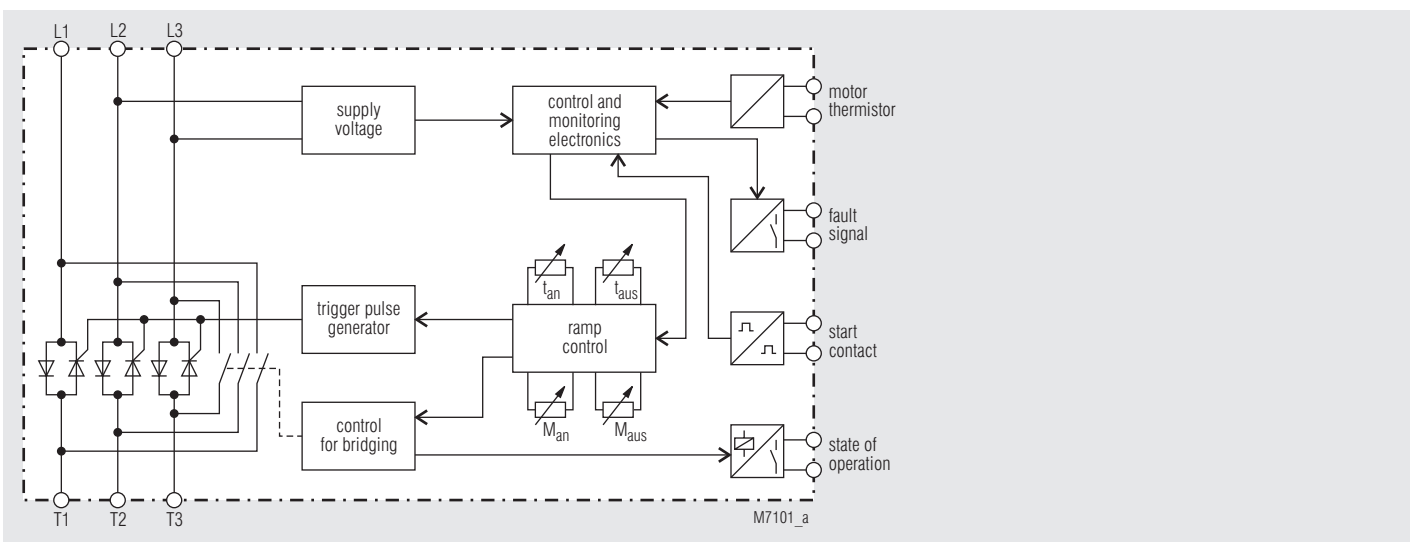

## Principle of Operation

For direct on line or start delta applications, terminals L1, L2, L3 are connected to the mains contactor, with the motor connected to terminals T1, T2, T3 and a 24 V DC control signal is connected to terminals 6-7

When power is connected to terminals L1, L2, L3 and 24 V DC is present at terminals 6-7, the softstart will commence. Potentiometer "t<sub>an</sub>" (1-20 sec.) adjusts the ramp time (time motor takes to get to full speed) and potentiometer "M<sub>an</sub>" adjusts the start voltage (0 - 80 % nomV). When the softstart is complete the internal semi-conductors are automatically bridged.

When 24 V DC is removed from terminals 6-7, the softstop function will commence for the deceleration time period set on potentiometer "t<sub>ab</sub>" (0 - 20 sec.) and deceleration voltage level set on potentiometer "M<sub>ab</sub>" (20 - 80 % nomV).

## Notes

Motor load must always be connected as continuous operation of the softstart with no load may cause overheating of the motor and softstart.

It is recommended that the softstart is protected by superfast semi-conductor fuses rated as per the current rating of the softstart or motor. However, standard line and motor protection is acceptable, but for high starting frequencies motor winding temperature monitoring is recommended.

## Standard Type

GE 9015	3 AC 400 V	50/60 Hz	22 kW	
Article number:			0047805	stock item
• Nominal voltage:	3 AC 400 V			
• Rated motor power:	22 kW			
• Width:	235 mm			

## Ordering Example

GE 9015	3 AC 500 V	50/60Hz	11 kW	AC 230 V	
					Auxiliary supply (only for voltages > 500 V)
					Rated motor power
					Nominal frequency
					Nominal voltage
					Type

## Technical Data

Nominal voltage: (others on request*)	3 AC 400 V ± 15 %						
Nominal frequency:	50/60 Hz						
Nominal current:	16 A	25 A	32 A	48 A	63 A	75 A	105 A
Max. rated motor power at 400 V:	7.5 kW	11 kW	15 kW	22 kW	30 kW	37 kW	55 kW
Min. motor power:	approx. 0.1 PN						
Starting torque:	0 ... 80 %						
Ramp time:	1 ... 20 s						
Deceleration torque:	20 ... 80 %						
Deceleration time:	0 ... 20 s						
Recovery time:	200 ms						
Switching frequency:	100 / h	100 / h	80 / h	60 / h	60 / h	40 / h	20 / h
Cable diameter at control terminals:	1.5 mm <sup>2</sup>						
Cable diameter at load terminals:	16 mm <sup>2</sup>				35 mm <sup>2</sup>		
External superfast semiconductor protection fuse:	80 A	100 A	125 A	160 A	200A	250 A	450 A
Temperature range / Storage temperature:	0°C ... 45°C / - 25°C ... 75°C						
Weight:	3.8 kg	3.8 kg	4 kg	4 kg	7.8 kg	8 kg	8.2 kg

\* For voltages over 500 V an external auxiliary supply is necessary and has to be connected to terminals 1 and 3. AC 230 V or DC 24 V is possible.

## Dimensions

Rated power	Device dimension width x height x depth	Fastening dimension for M4 screws width x height
7.5 kW, 11 kW, 15 kW, 22 kW	235 x 245 x 140 mm	218 x 170 mm
30 kW, 37 kW, 55 kW	335 x 245 x 170 mm	318 x 170 mm

## Installation

The device must be mounted on a vertical mounting area with the connections in a vertical plane, i.e. top to bottom.

Ensure that no external heat source is placed below the unit and a 50 mm air gap is maintained above and below. Other devices may be directly mounted either side of the unit.

## Connection

The mains-, motor- and control cables should be wired separately. For longer distances the control cables should be screened. To obtain radio screening to degree "N" a filter should be installed into the mains line as near as possible to the softstart unit.

EMC:

The GE 9015 is manufactured according to current standards for softstarters, but within the area of 10 m receivers and sensitive electronic devices may be effected.

If such disturbances occur from the operation of the softstarter GE 9015 these emissions can be reduced:

connecting an inductance (3 mH) in front of the softstart device, x-capacitors (0.15 µF) across the supply terminals or by installing a mains filter.

## Control Input

1. Voltage free contact:  
When the voltage free contact across terminals 6 and 7 is closed, the softstart function will commence. When the contact is opened, the softstop function will commence.
2. DC-control voltage  
In order to control the acceleration or deceleration of the unit by a PLC, the GE 9015 is equipped with a voltage-free DC control input.  
To enable this function remove the plexiglass cover and put the corresponding jumper from position "K" to position "S".  
When a DC voltage (DC 10 ... 42 V) is applied to the terminals 7 (+) and 6 (-), the softstart function will commence. When this voltage is removed, the softstop function will commence.
3. A motor thermistor can be connected to terminals 4 and 5. If this function is not required these terminals should be bridged.

## Monitoring Output

9 / 10:

State of operation: Contact is closed when the semi-conductors are bridged or alternatively from beginning of softstart till end of softstop  
To enable this function remove the plexiglass cover and put the corresponding jumper from position "U" to position "B".

11 / 12:

Fault signal: Contact opens when device faulty or motor overheated

Contact load: for each contact AC 250 V / 8 A

## Set-up Procedure

Set potentiometer "M<sub>an</sub>" to minimum (fully anti-clockwise).  
Set potentiometer "M<sub>ab</sub>" to maximum (fully clockwise).  
Set potentiometer "t<sub>an</sub>" to maximum (fully clockwise).  
Set potentiometer "t<sub>ab</sub>" to maximum position (fully clockwise).  
Start the motor and turn potentiometer "M<sub>an</sub>" up until the motor starts to turn without excessive humming.  
stop the motor and restart.  
Adjust potentiometer "t<sub>an</sub>" to give the desired ramp time.  
Stop and restart the motor.  
Adjust potentiometer "M<sub>ab</sub>" until the motor starts to visibly slow down at the initiation of the softstop cycle.  
Restart and Stop the motor.  
Adjust potentiometer "t<sub>ab</sub>" to give the desired deceleration time.  
Restart and Stop the motor, readjusting the potentiometers until the desired starting/stopping characteristics are achieved.

- **Attention:** If the ramp-up time is adjusted to short, the internal bridging contact closes before the motor is on full speed. This may damage the bridging contactor or bridging relay.

## Safety Instructions

- Never clear a fault when the device is switched on
- **Attention:** This device can be started by potential-free contact, while connected directly to the mains without contactor (see application example). Please note, that even if the motor is at rest, it is not physically separated from the mains. Because of this the motor **must** be disconnected from the mains via the corresponding manual motor starter.
- The user must ensure that the device and the necessary components are mounted and connected according to the locally applicable regulations and technical standards.
- Adjustments may only be carried out by qualified specialist staff and the applicable safety rules must be observed.

## Application Examples

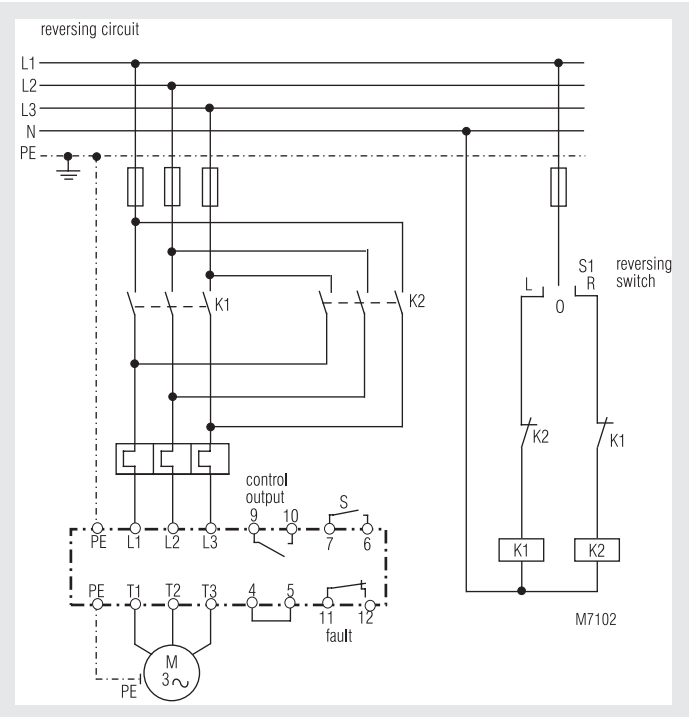

Softstart and softstop

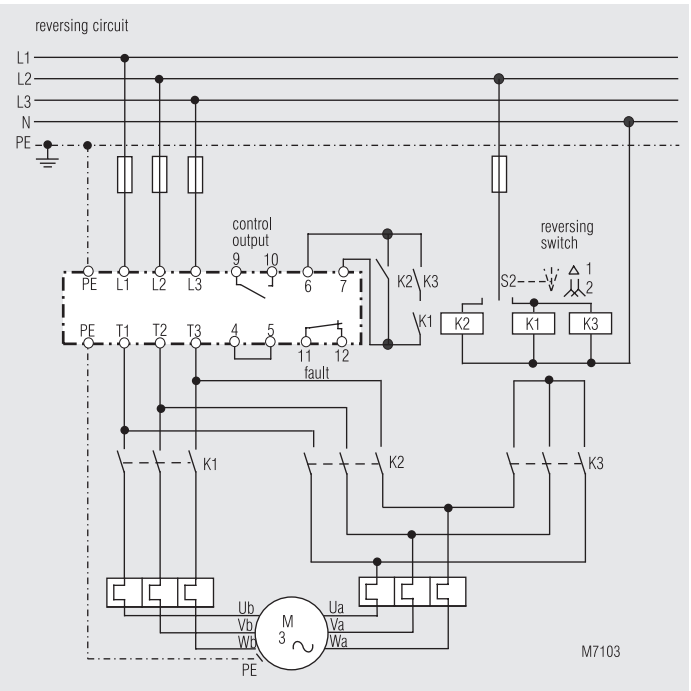

Softstart for "Dahlander" double speed motors

Attention: For this application turn potentiometer "t<sub>aus</sub>" to 0 as the softstop function cannot be used is not available.

